

Ready2Talk

How to connect a PA 64 to a REI Stereo

Many new Cutaway Minibuses now come with a REI stereo installed in the dash. Unfortunately, they only offer a hand mic, which is non-compliant in most States and Provinces. Generally, most operators just prefer to use a headset or a wireless headset anyway.

The “Minibus Headset Solutions” video on *Ready2Talk* our homepage offers 3 ways to connect a headset to an REI stereo, the most popular is to install a PA 64. Below are the instructions.

Quick Concept Explanation

The key point to understand is, the PA 64 is connected between the stereo’s output and the factory installed speakers. Luckily, because of the standard car stereo wire colour codes, adding a PA 64 to the REI stereo is quite simple.

Depending on the model of REI stereo, some will come with RCA audio output jacks, so a simple RCA to RCA cable connects the input in seconds. Others don’t, so in that case the stereo’s speaker output wires will connect to the PA 64 input using the included speaker wire to RCA pigtails.

REI Stereos with RCA Audio Output (see Diagram 1)

1. Remove the REI stereo from the dash exposing the back.
2. Connect one end of the RCA cable to the Front Channel RCA output and the other to the PA 64 RCA input. Set the input switch on the PA 64 to LOW. (The input is done)
3. You’ll notice that there are a Yellow, Red and Black power wires on the PA 64 master harness. Connect them to the same-coloured wires that feed the REI stereo. (The power is done)
4. This leaves the only the speaker connections. You’ll notice that the stereo and PA 64 use the same-coloured speaker wires.

One by one, cut all the 8 speaker wires from the REI stereo and reconnect to the same-coloured wire on the PA 64 master harness. Gray to Gray, Gray/Black to Gray/Black... White, Green and Purple wires.

5. Reinstall the stereo and mount the PA 64. Remember, if you mount the PA 64 under the dash, there is an extra front stick to make the printing the proper way up.

You’re done!

REI Stereos without RCA / Speaker wires only (see Diagram 2)

For simplicity and understanding, we'll flip the procedure around a bit.

1. Remove the REI stereo from the dash exposing the back.
2. You'll notice that there is a Yellow, Red and Black power wires on the PA 64 harness. Connect them to the same-coloured wires that feed the REI stereo. (The power is done)
3. You'll notice that the stereo and PA 64 use the same-coloured speaker wires.

One by one, cut all the 8 speaker wires from the REI stereo and reconnect to the same-coloured wire on the PA 64 master harness. Gray to Gray, Gray/Black to Gray/Black... (Once you complete all 8 the speaker wires are done)

4. This leaves the 8 output wires from the stereo.

Using the 2 x RCA to speaker wire pigtails that come in the PA 64 box, connect the pigtail's Gray wire to the Gray wire coming out of the stereo. Do the same for the Gray/Black, White, and White/Black wires.

This leaves the Green and Purple pairs of wires coming out of the stereo.. These are not use in this installation so safely tape them up so they don't short to anything.

5. Reinstall the stereo and mount the PA 64. Remember, if you mount the PA 64 under the dash, there is an extra front stick to make the printing the proper way up.

You're done!

Wrapping up

I'm sure you found it's simpler than you first thought. Like every new item, the first installation will take a bit longer, the rest you can do in your sleep. BUT... if you have ANY questions, please don't fight with it, just give us a quick call.

The *Ready2Talk* Team
888 724-5351

Diagram 1

PA 63 - PA 64 connected to Aftermarket Stereo using RCA cables

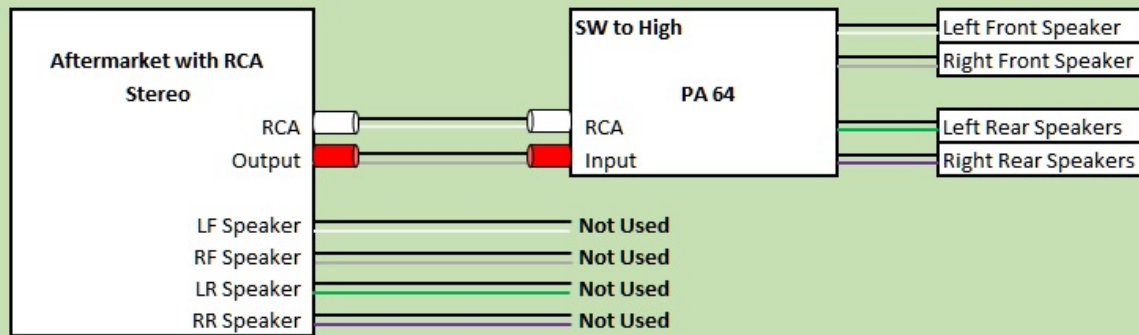

Diagram 2

PA 63 - PA 64 connected to Factory OEM Stereo using speaker wire pig tails

